

CH111CALA



Desktop Smart Charger+Calibrator Instructions for use

The CH111CAL is a 4-bay desktop smart battery charger comprised of 4-single CH1000CAL chargers, and is designed to achieve a maximum allowed state of charge (SOC) of 25% of 4 battery packs simultaneously. It has the added ability to recalibrate the fuel gauge on smart battery packs. It works with all Inspired Energy® brand “N” Series smart standard packs and hybrids irrespective of size, shape, voltage, cell chemistry or capacity.

What’s in the box?

1. One CH111CAL 4-bay desktop charger/calibrator
2. Three plastic spacers per bay to modify the battery bay to suit your battery size
3. One mains cable
 - N. American chargers (CH111CALA) are packed with a US 3-pin mains cord

Safety:

1. Do not expose the charger or power supply to water or liquids.
2. Do not open the charger or power supply case, no user serviceable parts are inside.
3. Do not cover the fan exhaust or obstruct the airflow, this will cause overheating.
4. Place the charger in a cool spot, away from external heat sources.
5. Caution - during recalibration the charger may become warm.

Using your Charger:

Place the charger on a flat, level surface away from sources of heat and moisture. Plug the supplied mains AC cord into the back of the charger. The fans turn on, and all LEDs illuminate for two seconds on power up.

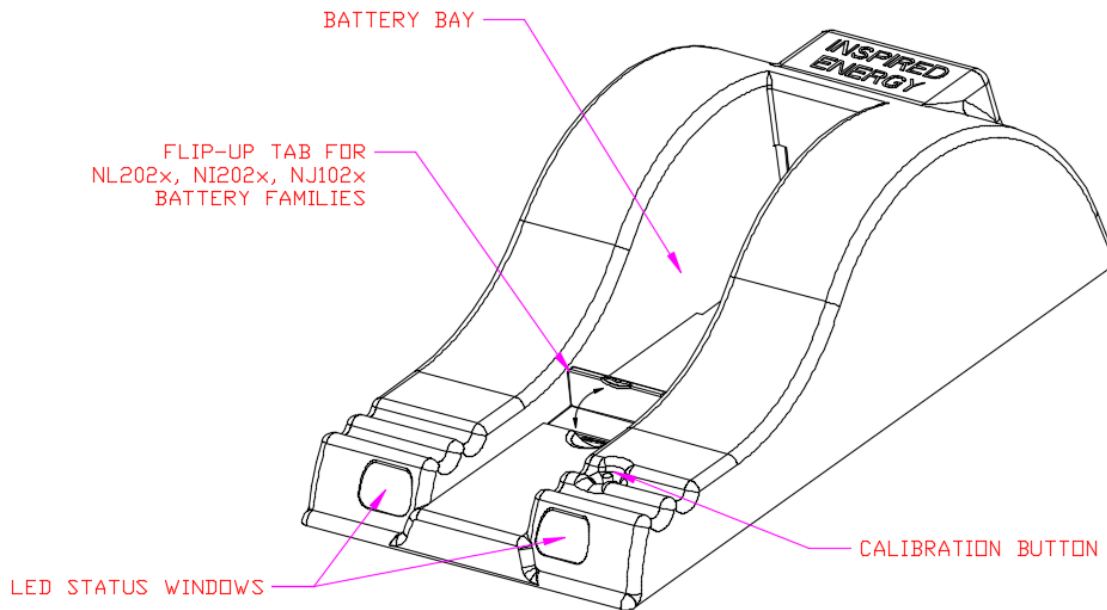

Using the Plastic Spacers:

Plastic spacers are supplied to assist in the correct insertion of all of the different sizes of smart standard packs. To insert a spacer, place the bottom of the spacer in the rear corner of the battery bay. Place a thumb on the top of the spacer and push it firmly towards the back of the charger. Correct insertion should be accompanied by a click as the guides lock into place. The cross reference of spacers to batteries is given below:

Thick “L” shaped spacer:	NC2560, NI1030, ND2017, Ni2020 Style
Thin “L” shaped spacer:	NL2020 & NL2024 Style
Flat spacer:	203x, 204x, and 2050x
No spacer is required for the 40xx ranges of batteries.	

Charging:

The LEDs in the each status window will provide status information of its respective battery pack, and the associated charger will automatically begin charging.

1. To set the charge for shipping: Insert a battery pack ensuring that the 5-way connector is fully seated. It will automatically either charge or discharge the battery to 25% state of charge (SOC) as required under the IATA guidelines for shipping Li-ion batteries. When completed, a solid green LED will light.
2. To calibrate and fully charge: Insert a battery pack ensuring that the 5-way connector is fully seated. Press the calibration button once, and the blue LED will begin flashing. This will initiate a calibration cycle for the fuel gauge, then fully charge the battery. When completed, the blue LED will be solid.

LED Indication:

The status of the battery is indicated by the LEDs visible in the status window:

* Green flashing:	Battery charging
● Green solid:	Charge complete (to 25% SOC)
* Blue flashing:	Battery in calibration mode
● Blue solid:	Battery fuel gauge calibrated
* Red flashing:	Battery fuel gauge needs recalibration
● Red solid:	Error

Charge Time:

Charge times to 25% SOC differ depending on battery capacity and state of charge when routine first begins, but should complete in less than one hour.

Recalibration Time:

Recalibration consists of a calibration charge, followed by a calibration discharge. Finally the battery is given a regular charge. A calibration cycle will be faster if the battery is fully charged to begin with. Recalibration time is governed by the battery voltage and capacity. Larger batteries and lower voltage batteries will take longer to recalibrate. Calibration is initiated each time the button is pressed, so it is not recommended to press the recalibration button part way through the recalibration cycle. The built-in fans will turn on only during discharge of a battery.

Battery Chemistry	Battery Model	Recalibration Time (hours)
NiMH	NI1030, NJ1020	5 - 7
Li-ion	NC2040, NC2560, ND2054, ND2034	16 - 20
	ND2053	44 - 50
	NB2037, ND2017	25 - 31
	ND2037, ND2057	22 - 25
	NF2040, NF2030	20 - 23
	NF2047	29 - 34
	NH2057	33 - 40
	NH2054, NH2034	18 - 21
	NI2020, NI2040, NL2020, NL2050, NL2024, NL2044, NL2054, RH2024, RH2044, RH2054, RI2020, RI2050	18 - 26
	NB4037, NC4040, ND4054, NE4068	16 - 20

What are the SMBus and the SBS?

The Smart Battery System defines the parameters that are stored by an SBS-compliant battery. These parameters include full battery status and fuel gauging information. The System Management Bus is the language by which these parameters are communicated between the battery, the charger and the host device. For full details of the SBS information available from your battery please refer to the battery specification sheet available at www.inspired-energy.com.

How does the charger know what charge to deliver?

Each charger unit is capable of sensing and delivering an appropriate charge to all Inspired Energy NiMH and Li-ion “N” Series standard battery packs. Upon inserting the battery into the charger, the battery communicates to the charger over the SMBus telling the charger what type of cell chemistry it is and what type of charge regime it needs. The charger then configures its output to provide the charge regime requested by the battery. If no SMBus communications are issued from the battery, the charger interrogates the thermistor/resistor I.D. pin on the battery terminal and delivers an appropriate charge.

Compatibility:

The CH1111CAL is fully compatible with all Inspired Energy® brand “N” Series standard battery packs and their custom hybrids. For optimum results we recommend using only Inspired Energy® brand batteries. For a full list of all compatible Inspired Energy batteries, please visit:

www.inspired-energy.com

CH1111CALA/E/U/X Specification Summary

Weight:	3.924kg / 138.415oz
Height:	127mm / 5"
Length:	400mm / 16"
Width:	118mm / 8"
Mating Connector:	5-blade standard battery connector
Communications Complies:	System Management Bus Rev 1.1, Smart Battery Data Specification Rev 1.1 and Smart Battery Charger Specification Rev 1.1 compliant
Power Supply:	90-260VAC, 26V, 2.5A DC, 119x38x60mm, 500g / 18oz UL listed, CE Compliant
Mains Cord:	CH1111CALA - 110V N. American 3-pin connector

