

# CH1000A/E/U/X



## Desktop Smart Charger+Calibrator Instructions for use

The CH1000 is a standalone desktop smart, standard battery charger with the added ability to recalibrate the fuel gauge on smart battery packs. It works with all Inspired Energy® brand “N” Series smart standard packs and hybrids irrespective of size, shape, voltage, cell chemistry or capacity.

### What’s in the box?

1. One CH1000 desktop charger/calibrator
2. Three plastic spacers to modify the battery bay to suit your battery size
3. One 26V 2.5A DC power supply with universal mains input
4. One mains cable
  - N. American chargers (CH1000A) are packed with a US 3-pin mains cord
  - European chargers (CH1000E) are packed with a European 2-pin mains cord
  - UK chargers (CH1000U) are packed with a UK 3-pin mains cord
  - CH1000X chargers are not packed with a mains cord

### Safety:

1. Do not expose the charger or power supply to water or liquids.
2. Do not open the charger or power supply case, no user serviceable parts are inside.
3. Do not cover the fan exhaust or obstruct the airflow, this will cause overheating.
4. Use only the manufacturer’s power supply and observe terminal polarity.
5. Place the charger in a cool spot, away from external heat sources.
6. Caution - during recalibration the charger may become warm.

## Using your Charger:

Place the charger on a flat, level surface away from sources of heat and moisture. Plug the DC connector from the power supply into the back of the charger and connect the power supply to the mains AC supply using the cable supplied. The fan turns on, and all LEDs illuminate for two seconds on power up.

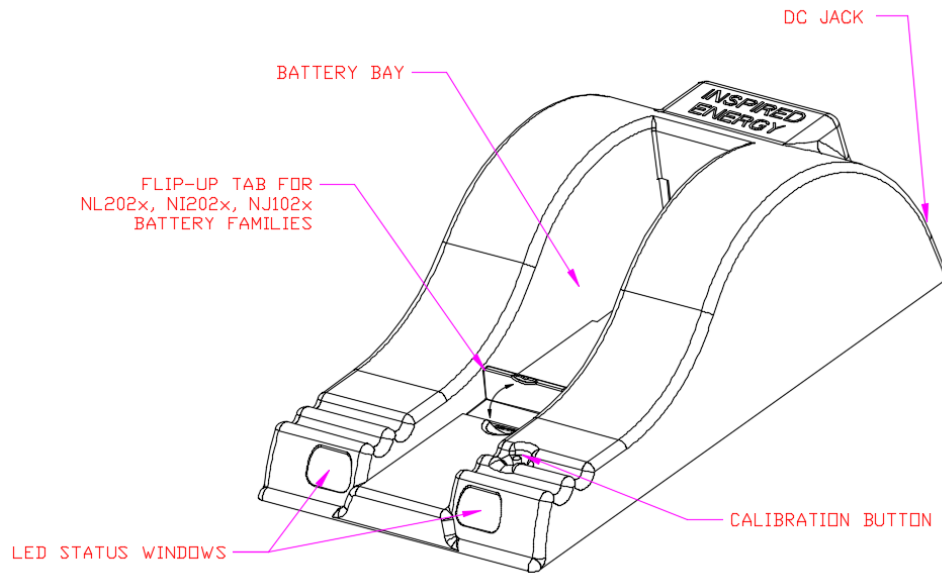

## Using the Plastic Spacers:

Plastic spacers are supplied to assist in the correct insertion of all of the different sizes of smart standard packs. To insert a spacer, place the bottom of the spacer in the rear corner of the battery bay. Place a thumb on the top of the spacer and push it firmly towards the back of the charger. Correct insertion should be accompanied by a click as the guides lock into place. The cross reference of spacers to batteries is given below:

Thick "L" shaped spacer:	NC2560, NI1030, ND2017, Ni2020 Style
Thin "L" shaped spacer:	NL2020 & NL2024 Style
Flat spacer:	203x, 204x, and 2050x
No spacer is required for the 40xx ranges of batteries.	

## Charging:

Place the battery into the battery bay ensuring that the 5-way connector is fully seated. The LEDs in the status window will provide status information and the charger will automatically begin charging.

## LED Indication:

The status of the battery is indicated by the LEDs visible in the status window:

* Green flashing:	Battery charging
● Green solid:	Battery fully charged
* Blue flashing:	Battery in calibration mode
● Blue solid:	Battery fuel gauge calibrated
* Red flashing:	Battery fuel gauge needs recalibration
● Red solid:	Error

## Recharge Time:

Different battery packs will require differing recharge times. The times given below are for a full charge from 0% to 100% state of charge. They are valid for all variants and custom hybrids of each battery model.

Battery Chemistry	Battery Model	Recharge Time (hours)	Recalibration Time (hours)
NiMH	NI1030, NJ1020	2.5	4 - 6
Li-ion	NC2040	2.5	26 - 28
	NC2560, ND2054, ND2034	2.5 - 3	11 - 15
	ND2053	6.5	49 - 50
	NB2037, ND2017	3	16 - 18
	ND2037, ND2057	3	12 - 18
	NF2040, NF2030	3 - 3.5	12 - 14
	NF2047	4.5	23 - 25
	NH2057	3	24 - 26
	NH2054, NH2034	3 - 3.5	12 - 17
	NI2020, NI2040, NL2020, NL2050, NL2054	3 - 4	15 - 20
	NL2024, NL2044	3 - 4	7 - 12
	NB4037, NC4040	3 - 5	12 - 18
	ND4054, NE4068	3	28 - 30

## Recalibration Time:

Recalibration consists of a calibration charge, followed by a calibration discharge. Finally the battery is given a regular charge. A calibration cycle will be faster if the battery is fully charged to begin with. Recalibration time is governed by the battery voltage and capacity. Larger batteries, and lower voltage batteries will take longer to recalibrate. Calibration is initiated each time the button is pressed, so it is not recommended to press the recalibration button part way through the recalibration cycle. The built-in fan will turn on only during a discharge of the battery.

## What are the SMBus and the SBS?

The Smart Battery System defines the parameters that are stored by an SBS-compliant battery. These parameters include full battery status and fuel gauging information. The System Management Bus is the language by which these parameters are communicated between the battery, the charger and the host device. For full details of the SBS information available from your battery please refer to the battery specification sheet available at [www.inspired-energy.com](http://www.inspired-energy.com).

## How does the charger know what charge to deliver?

The CH1000 charger is capable of sensing and delivering an appropriate charge to all Inspired Energy NiMH and Li-ion "N" Series standard battery packs. Upon inserting the battery into the charger, the battery communicates to the charger over the SMBus telling the charger what type of cell chemistry it is and what type of charge regime it needs. The CH1000 then configures its output to provide the charge regime requested by the battery. If no SMBus communications are issued from the battery, the charger interrogates the thermistor/resistor I.D. pin on the battery terminal and delivers an appropriate charge.

## Compatibility:

The CH1000 is fully compatible with all Inspired Energy® brand "N" Series standard battery packs and their custom hybrids. For optimum results we recommend using only Inspired Energy® brand batteries. For a full list of all compatible Inspired Energy batteries, please visit:

[www.inspired-energy.com](http://www.inspired-energy.com)

## CH1000A/E/U/X Specification Summary

Weight:	300g / 11oz
Height:	58mm / 2¼"
Length:	180mm / 7"
Width:	92mm / 3½"
Mating Connector:	5-blade standard battery connector
Communications Compliances:	System Management Bus Rev 1.1, Smart Battery Data Specification Rev 1.1 and Smart Battery Charger Specification Rev 1.1 compliant
Power Supply:	90-260VAC, 26V, 2.5A DC, 119x38x60mm, 500g / 18oz UL listed, CE Compliant
Mains Cord:	CH1000A - 110V N. American 3-pin connector CH1000E - 220V European 2-pin connector with ground recess CH1000U - 240V UK 3-pin connector CH1000X - No AC cable supplied

